

PRODUCT SPECIFICATIONS

Elkay SwirlFlo® Single Wall Mount Fountain Vandal Resistant Non-Filtered Non-Refrigerated Stainless. Furnished with Vandal Resistant bubbler. Mechanical Front Bubbler Button activation. Product shall be Wall Mount (On Wall), for Indoor applications, serving 1 station(s).

Finish:	Stainless Steel
Power:	No Electrical Required
Bubbler Style:	Vandal Resistant
Activation by:	Mechanical Front Bubbler Button
Mounting Type:	Wall Mount (On Wall)
Chilling Capacity:	Non-refrigerated
Dimensions (L x W x H):	14" x 18-3/8" x 11-5/16"
Approx. Shipping Weight:	23 lbs.
Installation Location:	Indoor
No. of Stations Served:	1

- Mechanically-Activated bubbler continues to supply water in event of service disruptions.



Included with Product: Fountain with Back Plate, Surface Mounting

▼ Ships in multiple boxes.

A Century of Tradition and Quality. For more than 100 years, Elkay has been making innovative products and providing exceptional customer care. We take pride in offering plumbing products that make life easier, inspire change and leave the world a better place.

PRODUCT COMPLIANCE

- ADA & ICC A117.1
- ASME A112.19.3/CSA B45.4
- Buy American Act
- NSF/ANSI 61 & 372 (lead free)



[Installation Instructions \(PDF\) - 97921C](#)

Water Systems are warranted for 12 months from date of installation. **Warranty pertains to drinking water applications only. Non-drinking water applications are not covered under warranty.**

[Warranty \(PDF\)](#)

PART: _____ QTY: _____

PROJECT: _____



CONTACT: _____

DATE: _____

NOTES: _____

APPROVAL: _____

In keeping with our policy of continuing product improvement, Elkay reserves the right to change product specifications without notice. Please visit elkay.com for the most current version of Elkay product specification sheets. This specification describes an Elkay product with design, quality, and functional benefits to the user. When making a comparison of other producers' offerings, be certain these features are not overlooked.

Optional Accessories		
EWF172	Elkay Universal Filtration Kit (1500-Gallon) Spec Sheet (PDF)	
AP99	Elkay Access Panel 9" x 9" x 6" Spec Sheet (PDF)	
98481C	Bubbler Kit Water-Efficient Vandal-Resistant Spec Sheet (PDF)	

In keeping with our policy of continuing product improvement, Elkay reserves the right to change product specifications without notice. Please visit elkay.com for the most current version of Elkay product specification sheets. This specification describes an Elkay product with design, quality, and functional benefits to the user. When making a comparison of other producers' offerings, be certain these features are not overlooked.

INSTALLER NOTE

This drinking fountain is furnished with a bubbler and valve including all connecting fittings which are manufactured of completely lead free material. Shut off valve (not furnished) to accept 3/8" O.D. unplated copper tube.

OPERATION OF QUICK CONNECT FITTINGS

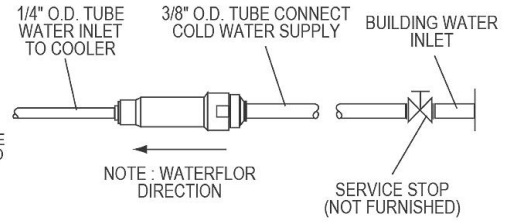
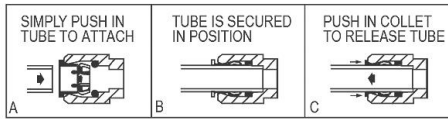

TOP VIEW

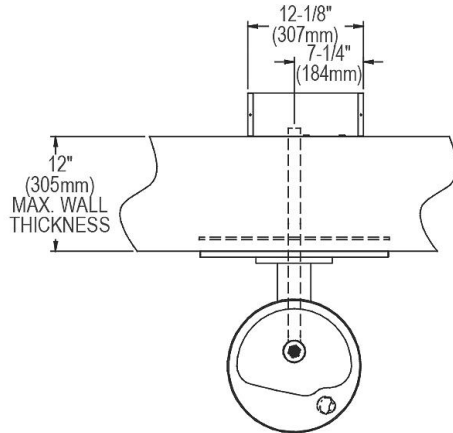

PUSHING TUBE IN BEFORE PULLING IT OUT HELPS TO RELEASE TUBE

WARNING: The free-resistant box must be installed on an interior heated wall where the temperature does not drop below 50° F (10° C). The front of the box must have unobstructed air flow. Failure to maintain the interior wall temperature and the inside of the freeze resistant box above 50° F (10° C) can result in damage to the box which could result in unrestricted water flow.

WALL LAYOUT

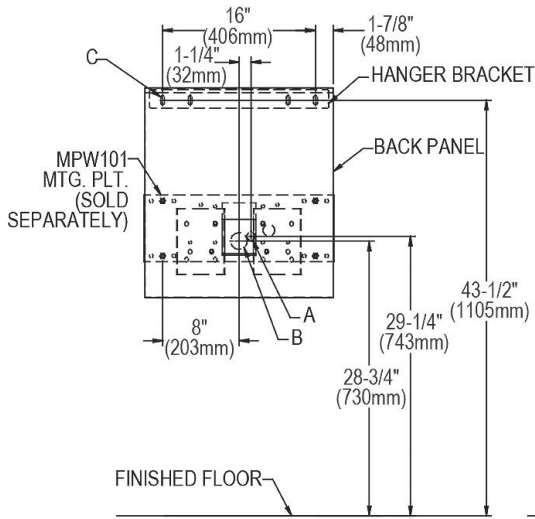

FRONT & SIDE VIEW

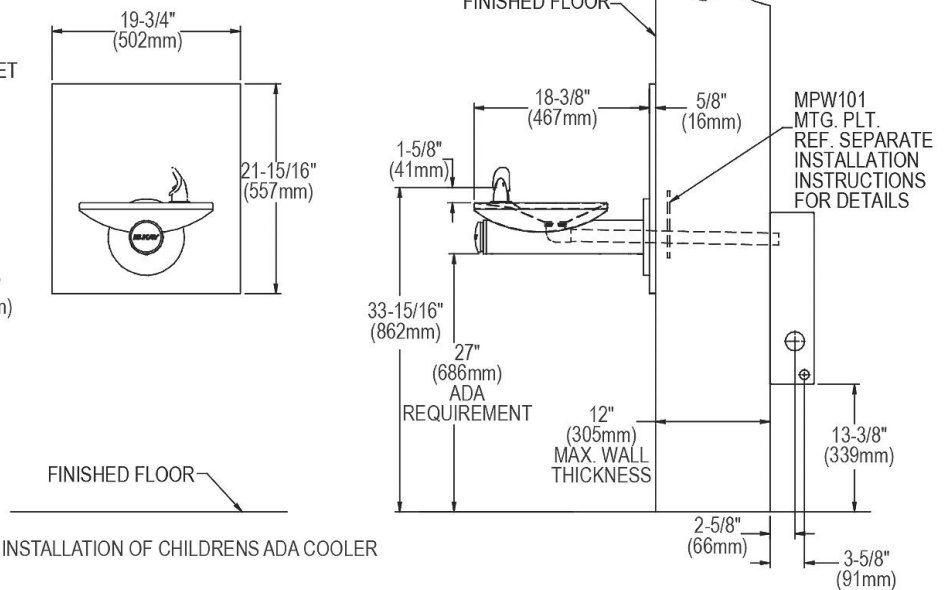

REDUCE HEIGHT BY 3 INCHES FOR INSTALLATION OF CHILDRENS ADA COOLER

LEGEND

- A = 7/8" (22mm) Ø Hole for water supply tube
- B = 1-3/4" (44mm) Ø Hole for waste line
- C = 3/8" (10mm) Ø Slots for mounting hanger bracket to wall

In keeping with our policy of continuing product improvement, Elkay reserves the right to change product specifications without notice. Please visit elkay.com for the most current version of Elkay product specification sheets. This specification describes an Elkay product with design, quality, and functional benefits to the user. When making a comparison of other producers' offerings, be certain these features are not overlooked.